

GIORDANO

VACCINATION DEVICES

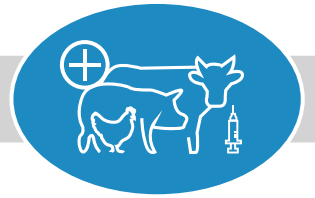

TECHNICAL BROCHURE

Manual Cabins

ELITE CAB-DUAL

Ref TB.3.00

ELITE CAB-DUAL

User-friendly pneumatic device designed for the application of live vaccines, offering high flexibility and simple operation:

- **Adjustable and lockable delivery volume from 5 to 30 ml;**
- **Different nozzle types** available, covering droplet sizes from **below 100 µm up to 300 µm**, suitable for all spray applications;
- **Wide nozzle movement range** to ensure complete and uniform coverage of the crates;
- **Two separate plastic tanks;**
- **Capable of applying two different vaccines in a single full cycle** (two spray moments during one single crate transit);
- **Adjustable built-in crate-locking mechanism** to prevent movement during the vaccination process;
- **Built-in mechanical counter;**
- **Optional vaccine-mixing feature available** (magnetic stirrer).

Medium / Small hatcheries

Operating pressure: 5 bar

Manual spray system

Up to 36000 birds / h

Spare parts available

2 separate pumping systems

Wide nozzle movement range

Integrated mechanical counter

2 separate vaccine tanks



GIORDANO

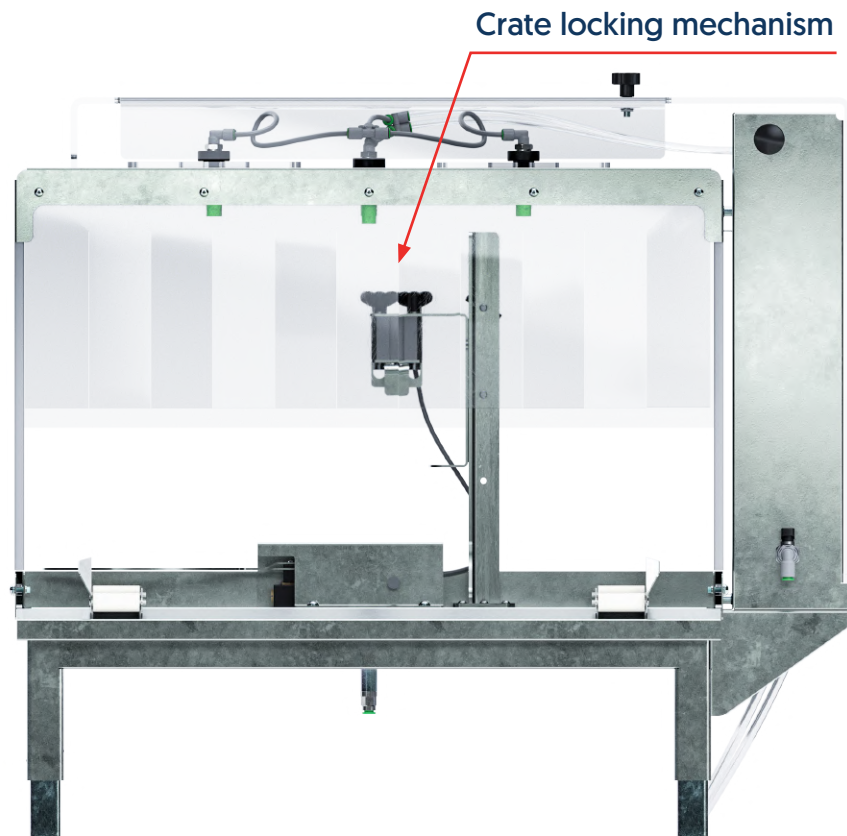

SPECIFICATIONS

ARTICLE CODE	0900171
SPEED	Up to 36000 chicks per hour
WEIGHT	39 kg
DIMENSIONS (H x D x L)	118 x 52 x 81 cm
MATERIALS	Stainless steel Rubber Polycarbonate
INCLUDED WITH	Extra nozzles Pneumatic oil 1 complete piston

NOZZLE COLOUR - DROPLET SIZE

NOZZLE CODE/COLOUR	TYPE	DROP SIZE	DISEASE
TXA8001VK ORANGE 	CONE 80°	120	IB
TXA80015VK GREEN 	CONE 80°	160	IB / ND
TXA8002VK YELLOW 	CONE 80°	200	COX
TXA8003VK BLUE 	CONE 80°	250	COX

Consider a tolerance of ± 20 microns when increasing or decreasing the operating pressure.



www.giordanoglobal.com
info@giordanoglobal.com

